

CDM COOLANT HEATING SYSTEM

The HOTSTART CDM is a complete, packaged heating system with pump, flow switch, thermocouples and all required controls. The CDM heats engines up to 1000L displacement at 50°C over ambient temperature. A text display screen allows operators to adjust and monitor water temperature and other vital system settings. Forced circulation of the coolant delivers uniform heating throughout the entire engine, extends element life and reduces electrical consumption.



CE

APPLICATION

The CDM was developed to preheat diesel and gas engines for stationary land power, marine, rail, large mining and construction equipment.

SPECIFICATIONS

- Heating Fluid: Engine coolant (50% glycol/50% water)
- Power: Up to 72kW (in two stages)
- Rated Voltage: 3Ø 400V, 480V, 575V, 690V (50 or 60Hz)
- Tank Material: Steel
- Thermostat: Adj. 60° - 160°F (16° - 71°C)
- Ingress Protection: IP54, NEMA 12 & 13
- Hi-Limit Cutout: 200°F (94°C)
- Fluid Capacity: 3.7 gal (14L)
- Pump Power: 2HP (Up to 1.5kW)
- Flow: 60GPM (13.5 m³/hr) @ 50ft head (1.5 bar)
- Max Pressure: 125PSI (8.61 bar)
- Pressure Loss: 1.5PSI (0.10 bar)
- Pressure Relief Valve: 90PSI (6.2 bar)
- 1.25" NPT Inlet, 1.25" NPT Outlet

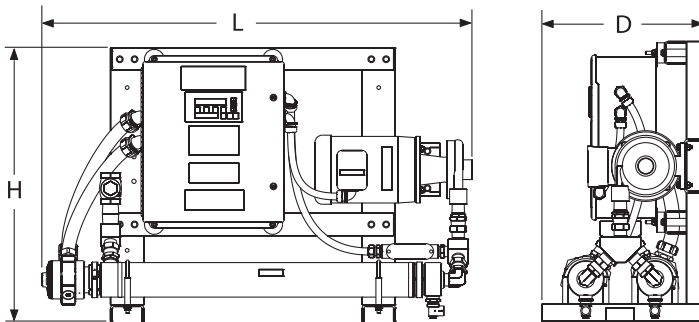

Dimensions & Weight

Height (H)	In (mm)	28.0	(711)
Length (L)	In (mm)	43.5	(1105)
Depth (D)	In (mm)	16.0	(406)
Weight	lbs (kg)	250	(113)

FEATURES

- Dual heating chambers
- CE compliant to LVD
- Designed and tested to meet DNV Marine Classification
- 24VDC relay for auto ON/OFF
- Auxiliary contacts for remote monitoring
- Optional E-stop connection
- Continuous Flow Monitoring

